

LF20W Fire alarm audio/visual warning panel Installation instructions

LF20W is an audio/visual warning panel, available in different models and suited for any emergency situation such as fire, flooding, gas leaks, etc., where visual and audio information is needed.

Assembly instructions

- Make four holes into the wall to fit the holders (Fig. 2 ①)
- Fix the mounting box with the four screws (Fig. 2 ②)
- Connect the power supply to the terminals (Fig. 1)
- If the sounder is not needed, connect the SILENT jumper (Fig. 1)
- Fix the central part to the mounting box with the four screws (Fig. 2 ③)
- Place and press the external cover and fix it by te screws (Fig. 2 ④)

Figure 1

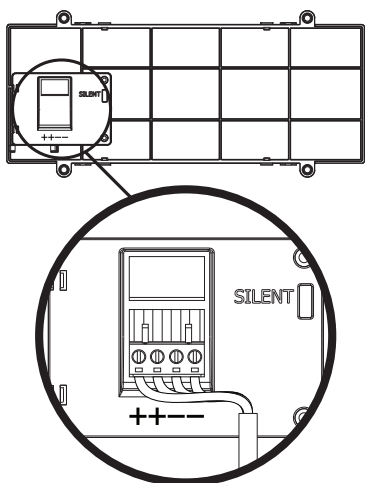
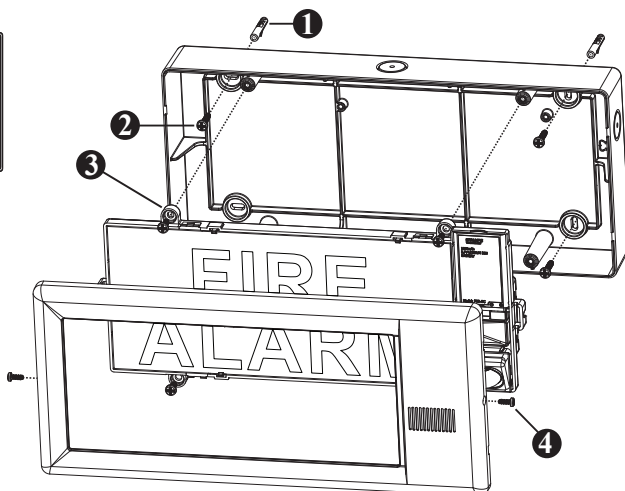

Figure 2



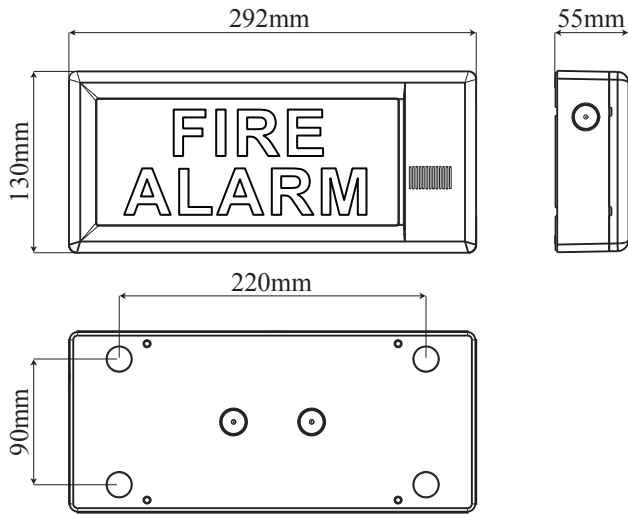
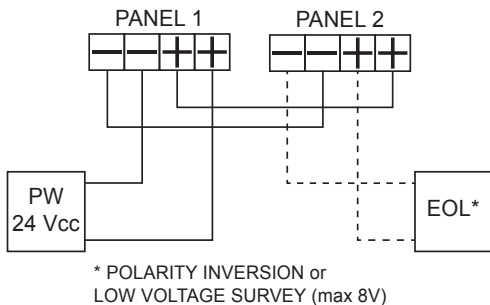

Figure A

Technical Specifications

Flammability Grade	V2
Protection Class	IP21C
Nominal Voltage	24 Vd.c (min 18Vd.c., max 30 Vd.c.)
Line Consumption 24V	21mA
Line Consumption 8V	10uA max
Type of Connection	By terminals
Dimensions	292x130x55mm (L x H x P)
Operating Temperature	Da -10°C a +55°C
Class	TYPE A
Sounder Specifications	Sound power (max, 90° V. plane): >90dB(A) @ 1m Buzzer frequency: 2,8KHz Sound pulse frequency: 1Hz

Connection



EN 54-3:2001 +
A1:2002 +
A2:2006

Synaps Technology Srl
Via Pietraferrata, 9/1
34147 - Trieste
ITALY